



OEM Efforts To Improve Fuel Consumption: **Tractor/Engine Perspective**

October 17, 2006



Truck and Engine Fuel Economy Improvements

Many Chassis, Body and Engine Improvements are Underway to Increase Heavy and Medium Duty Truck Fuel Efficiency

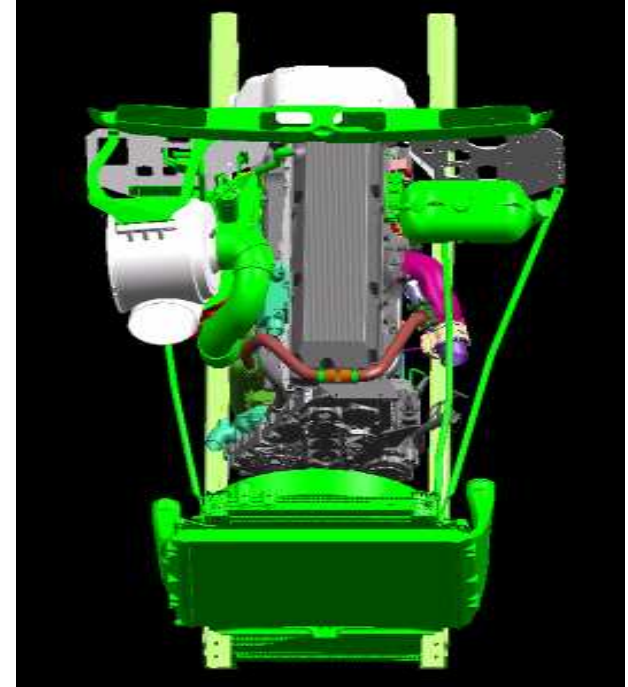
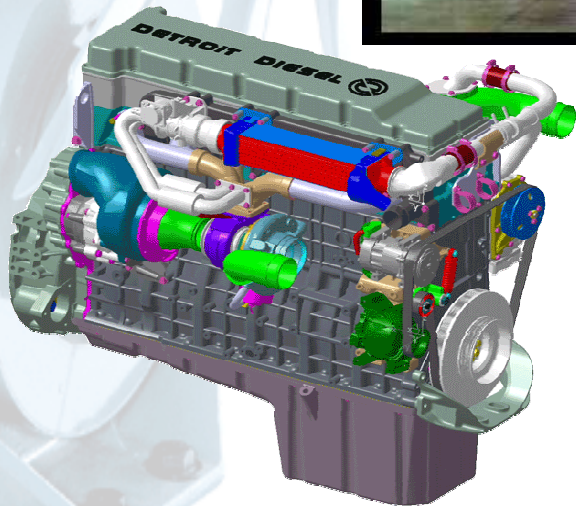

Truck and Engine Fuel Economy Improvements

Design Modifications to Optimize Air Flow Across Truck Exterior and Through Engine Compartment Will Deliver Significant Efficiency Gains



Truck and Engine Fuel Economy Improvements

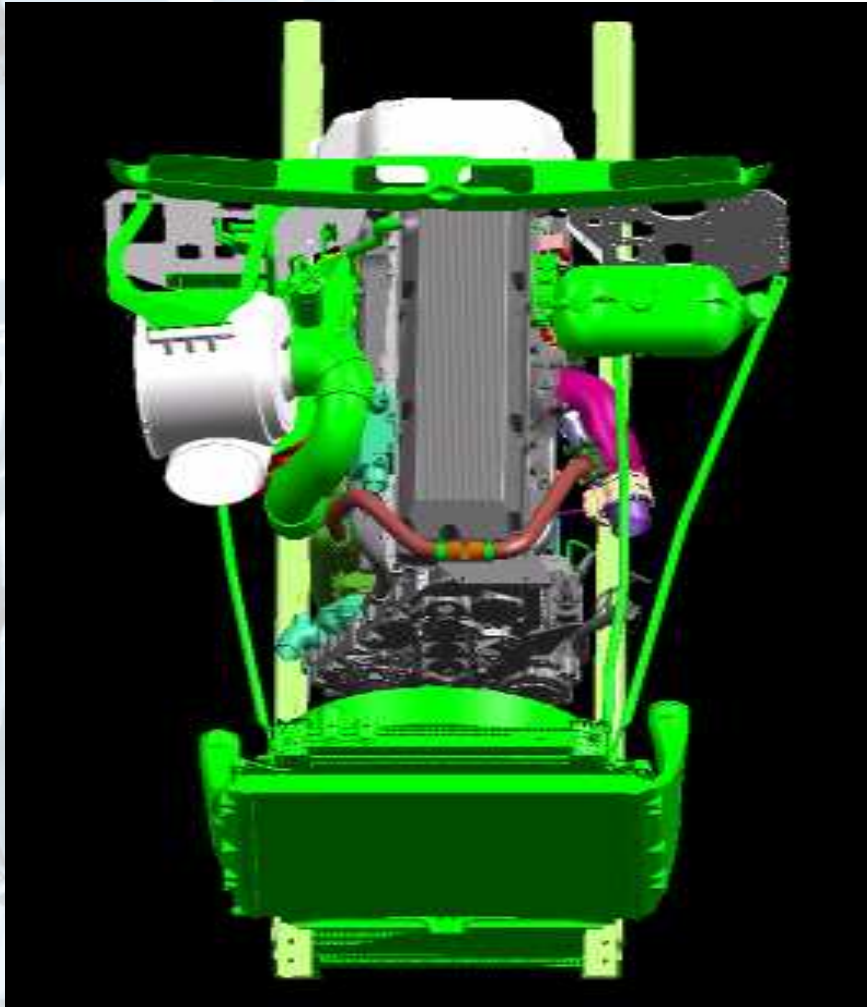

**Integrated, Larger-Capacity
Cooling System Modules
Increase Efficiency and Improve
Fuel Economy**

Truck and Engine Fuel Economy Improvements

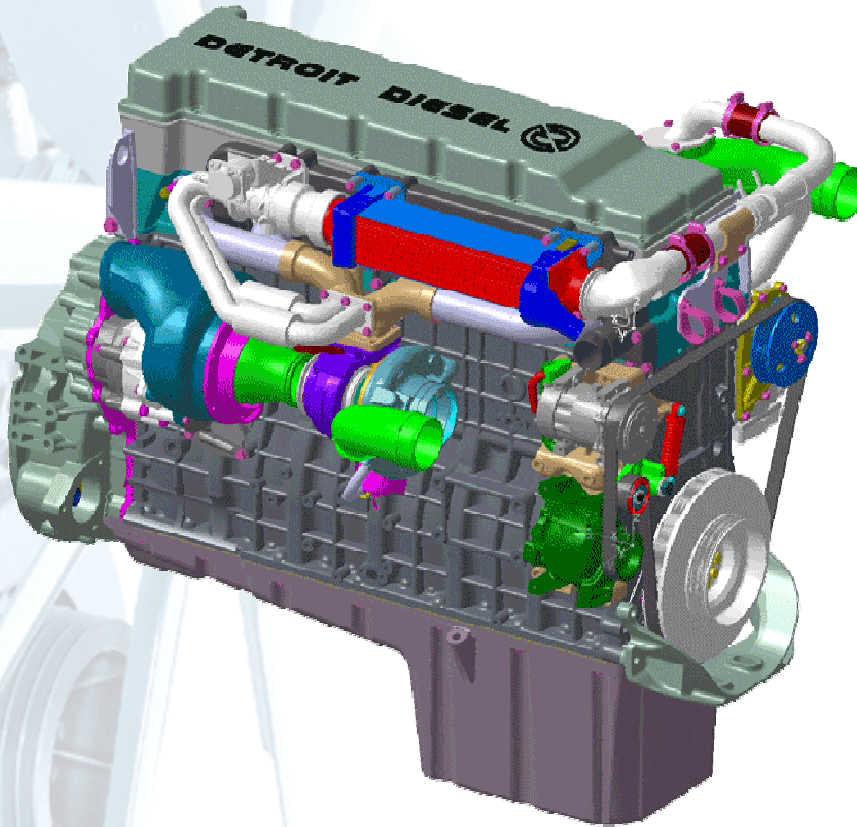

**All-New, Clean-Sheet-of-Paper
Engine Design Providing
Significant Fuel Economy Gains**



WE'RE READY!...

DETROIT DIESEL

CORPORATION

